

# Typ MZKU 90

mit zwei Zahnriemenantrieben an den Achsköpfen/  
with two belt drives at axis heads/doubles courroies  
et doubles chariots/con due cinghie dentate  
in corrispondenza delle teste dell'asse

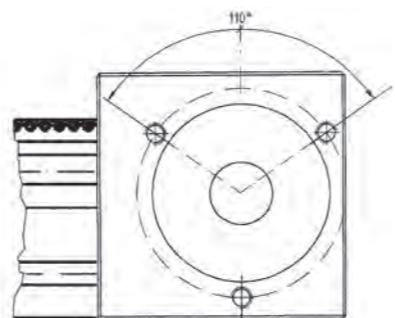

Option:  
Riemenführung MRF 90  
Belt Guide MRF 90  
Support retour courroie MRF 90

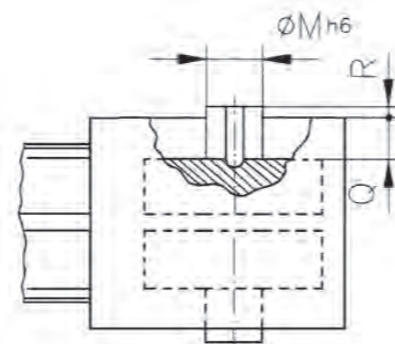
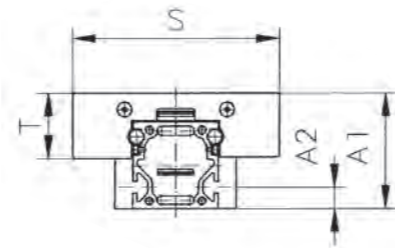
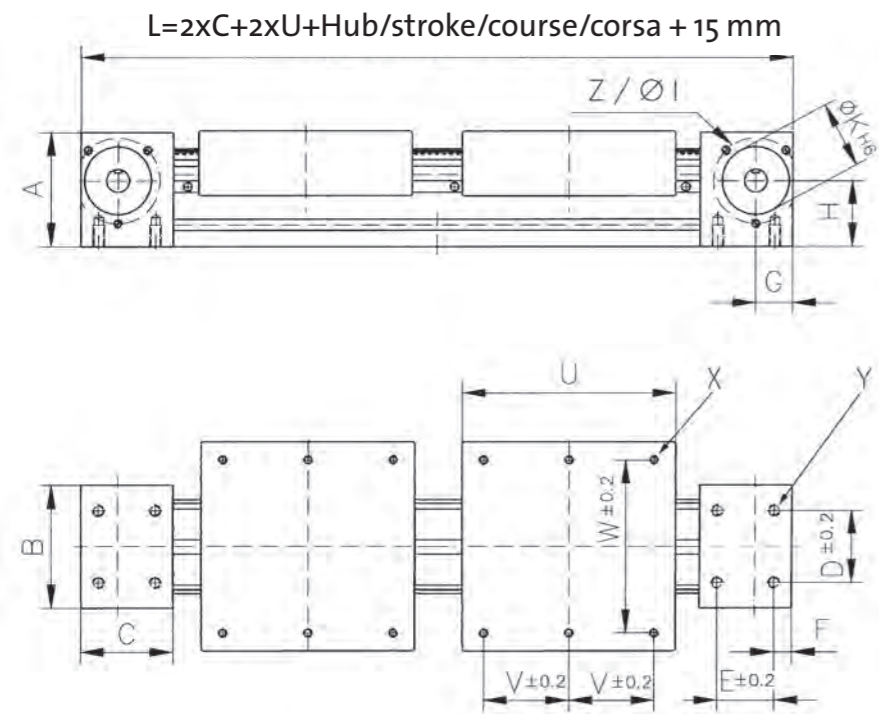
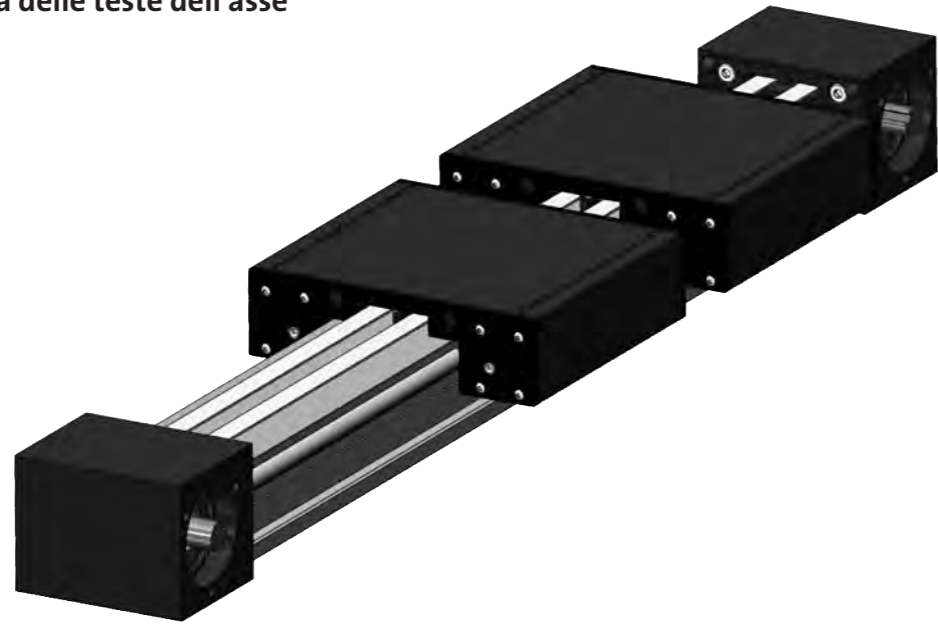
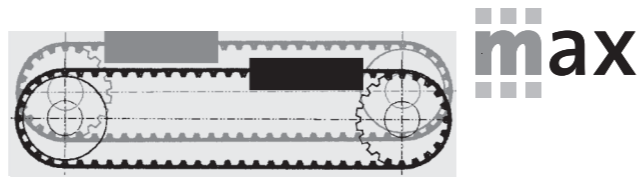
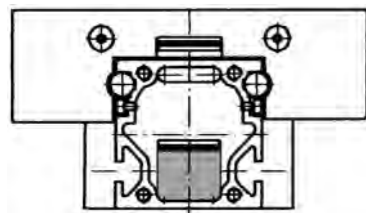

# Typ MZKU 90

mit zwei Zahnriemenantrieben an den Achsköpfen/  
with two belt drives at axis heads/doubles courroies  
et doubles chariots/con due cinghie dentate  
in corrispondenza delle teste dell'asse

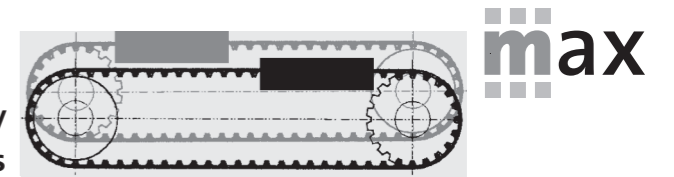

Linearachse/axis/axe/asse lineare

Typ	Profil	A x B x C	A1	A2	D x E	Y	F
MZKU 090	90 x 70	94 x 125 x 95	95	15	80 x 60	(4 x) M8 x 16	10

Anschluss für Antrieb/connection for drive/encombrement pour fixation/testata attacco motore

Typ	G x H	Ø I	Z	Ø K	Ø M	Q x R
MZKU 090	40 x 48	80	(3 x) M8 x 16	68	20	22 x 6

Schlitten/carriage/chariot/slitta

Typ	U	Rollen bearings galets	S x T	V	W	X	Gewicht/weight/poids/peso (kg)		
							2x Block 2x bloc	Schlitten chariot	Profil/m profile/m
MZKU 090	200	4	215 x 60	85 (2x)	185	M8 x 20	7,3	5,2	8,1
	300			135 (2x)				7,5	
	400	6		90 (4x)				9,8	
	500			117,5 (4x)				12	

Schlittenbelastungen (dynamisch)/carriage forces (dynamic)/force de chariot (dynamique)/forze sulla slitta (dinamico)

Achsprofil taille mm	Schlittenlänge chariot mm	Rollen bearings galets	für Last horizontal*	Fx(max) N	Fy(max) N	Fz(max) N	Mx(max) Nm	My(max) Nm	Mz(max) Nm			
90	200	4	100 kg	1400	6500	3800	190	250	500			
	300							375	600			
	400	6	100 kg					8500	5000	240	550	800
	500										700	1000

Fx (nominal) = Fx (max)/2

$$\left( \frac{F_y}{F_y(\max)} + \frac{F_z}{F_z(\max)} + \frac{M_x}{M_x(\max)} + \frac{M_y}{M_y(\max)} + \frac{M_z}{M_z(\max)} \right) \leq 1$$

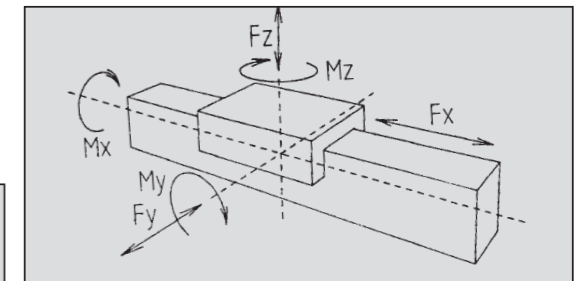

Bestellbeispiel:

MZKU 090.200.200.1000  
Typ MZKU  
Profilquerschnitt = 90 mm  
Schlittenlänge U = 2x200 mm  
Gesamtlänge L = 1000 mm

example of ordering:

MZKU 090.200.200.1000  
type MZKU  
section of profil = 90 mm  
length of carriage U = 2x200 mm  
total length L = 1000 mm

exemple de commande:

MZKU 090.200.200.1000  
type MZKU  
section du profil = 90 mm  
longueur du chariot U = 2x200 mm  
longueur totale L = 1000 mm

esempio di ordinazione

MZKU 090.200.200.1000  
tipo MZKU  
sezione profilo = 90 mm  
lunghezza slitta U = 2x200 mm  
lunghezza asse L = 1000 mm

# Typ MZKU 90

mit zwei Zahnriemenantrieben an den Achsköpfen/  
with two belt drives at axis heads/doubles courroies  
et doubles chariots/con due cinghie dentate  
in corrispondenza delle teste dell'asse

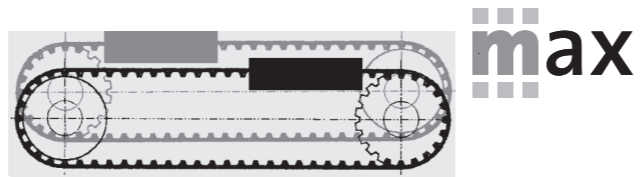

Linearachse	Umfang Riemen-scheibe mm	Durchmes-ser Riemen-scheibe mm	Leerlauf-moment Nm	Geschwindig-keit m/s bei 1000/min	max. An-triebs-moment Nm	Riemen-breite mm	Teilung mm	Zugkraft Fx (max)
Axis	periphery pully mm	dia pully mm	basic resi-stance Nm	speed m/s at 1000/min	max torque Nm	width of belt mm	pitch mm	traction load Fx (max)
Axe	perimètre poulie mm	diamètre poulie mm	couple résistant Nm	vélocité m/s à 1000/min	couple maximum Nm	largeur courroie mm	pas courroie mm	traction Fx (max)
MZKU 090	200	63,6	0,9	3,33	44	16	10	1400 N

$F_x \text{ (nominal)} = F_x \text{ (max)}/2$

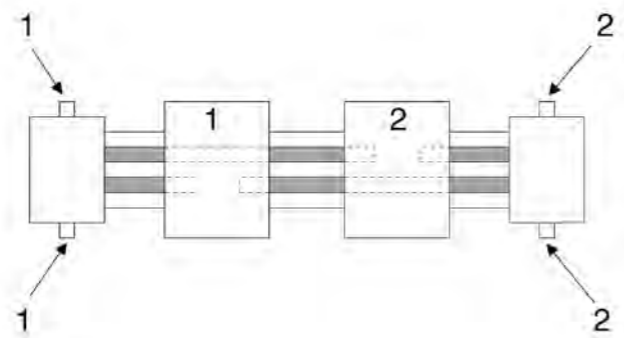

## Profilverstärkung MPV 090.MZK 090

Profile Reinforcement/Profil de renfort

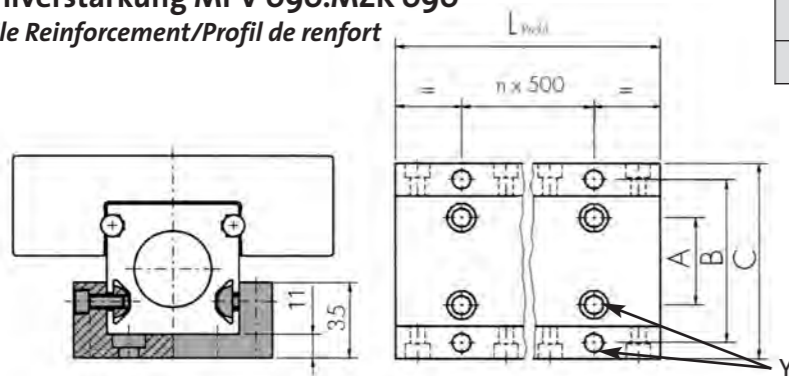

Typ	A	B	C	kg/m
MZKU 090	40	105	120	5,4



Y: für Schraube/for screw/pour vis/per viti M8, DIN 6912  
Inkl. Schrauben und Muttern für Achsen/Including screws and nuts for axis /  
Visserie comprise pour les axes/Compresi dadi e viti per gli assi

Bestellbeispiel:	example of ordering:	exemple de commande:	esempio di ordinazione:
MPV 090.2000 Typ MPV Achse = 090 L (Achspröfil) = 2000	MPV 090.2000 type MPV axis = 090 L (axis profile) = 2000	MPV 090.2000 tipo MPV axe = 090 L (profilo) = 2000	MPV 090.2000 tipo MPV asse = 090 L (profilo) = 2000

# Zubehör für Typ MZKU 090

accessories/accessoires/accessori



## Kupplung MKU

coupling/accouplement/giunto

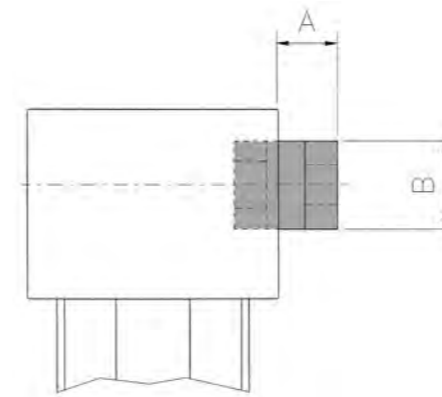

Typ	A	B	M <sub>nenn</sub>
MKU 090	48	40	17 Nm
MKU 090.1	60	55	60 Nm

Sonderkupplungen  
Special couplings  
Accouplements spéciaux  
Giunti speciali  
S./P. 58

## Antriebsflansch MAF

driving flange/bride d'adaption/flangia per motore

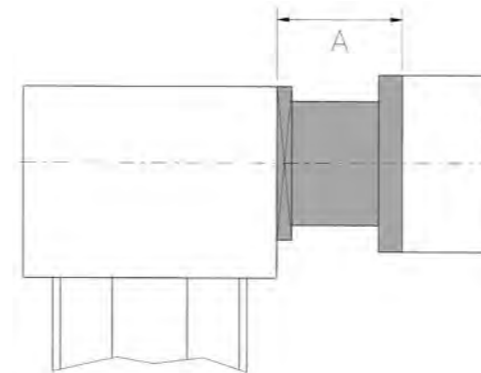

Typ	Getriebe	A/mm
MAF 090	MPG 90	78

Inkl. Schrauben für die Achse. Sonderflansche auf Wunsch/  
Including screws for axis. Special flange possible/  
Visserie comprise. Brides spéciales/  
Compresi viti per l'asse. Flangie speciali possibili.

## Option

Version .3

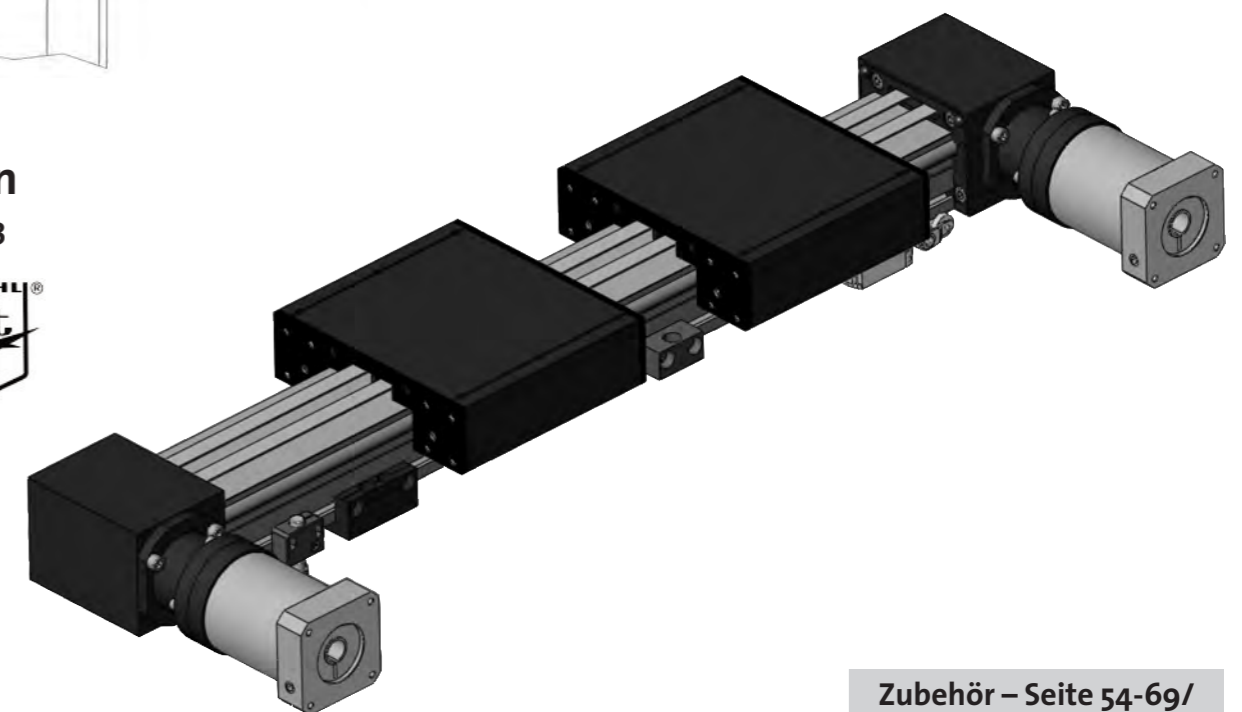

Zubehör – Seite 54-69/  
Options – page 54-69